



#### Product Summary

The GPL6232 series are a group of positive voltage regulators manufactured by CMOS technologies with ultra-low power consumption and low dropout voltage, which provide large output currents even when the difference of the input-output voltage is small. The GPL6232 series can deliver 300mA output current and allow an input voltage as high as 8V. The series are very suitable for the battery-powered equipments, such as RF applications and other systems requiring a quiet voltage source.

#### Features

- Low Quiescent Current: 0.8μA
- Operating Voltage Range: 1.8V~8V
- Output Current: 300mA
- Low Dropout Voltage: 110mV@100mA(VOUT=3.3V)
- Output Voltage: 1.2~5.0V
- High Accuracy: ±2%/±1%(Typ.)
- High Power Supply Rejection Ratio: 50dB@1kHz
- Low Output Noise: 27Xvout μVRMS(10Hz~100kHz)
- Excellent Line and Load Transient Response
- Built-in Current Limiter, Short-Circuit Protection

#### Applications

- Portable consumer equipments
- Radio control systems
- Laptop, Palmtops and PDAs
- Wireless Communication Equipments
- Portable Audio Video Equipments
- Ultra-low Power Microcontroller

#### Block Diagram

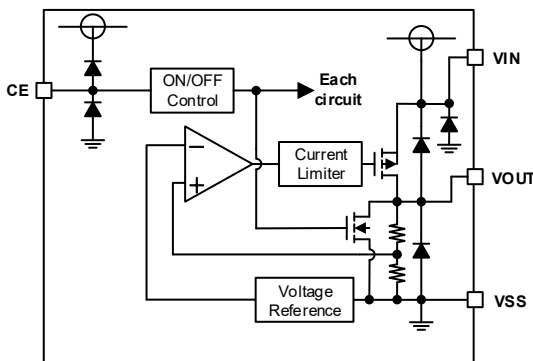

#### Order Information

GPL6232V①②

Designator	Description
①	Output Voltage e.g. 1.8V=①:V, ②:1, ③:8
②	Package: SOT-23-3L=K3 SOT-23-5L=K5 DFN1×1-4L=H1 SOT-89-3L=KE

## Pin Configuration

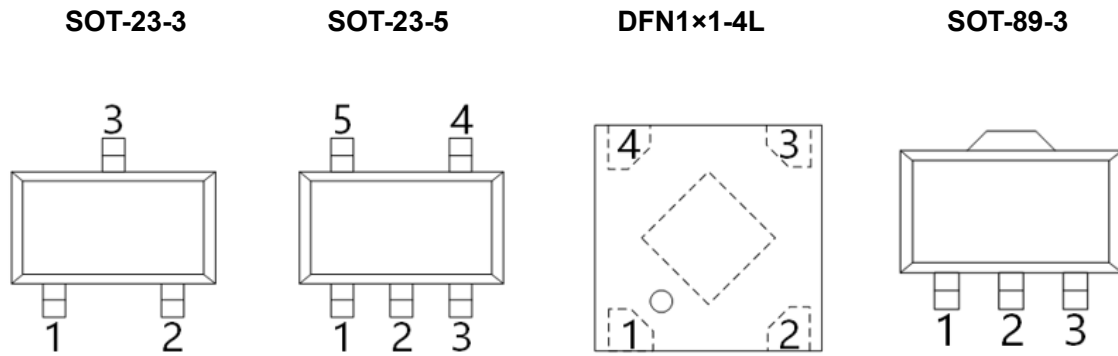

### SOT-23-3L & SOT-89-3L

Pin Number		Pin Name	Function
SOT-23-3L	SOT-89-3L		
1	1	$V_{SS}$	Ground
2	3	$V_{OUT}$	Output
3	2	$V_{IN}$	Power input

### SOT-23-5L

Pin Number	Pin Number	Function
1	$V_{IN}$	Power Input Pin
2	$V_{SS}$	Ground
3	CE	Chip Enable Pin
4	NC	No Connection
5	$V_{OUT}$	Output Pin

### DFN1x1-4L

Pin Number	Pin Number	Function
1	$V_{OUT}$	Output Pin
2	$V_{SS}$	Ground
3	CE	Chip Enable Pin
4	$V_{IN}$	Power Input Pin

## Absolute Maximum Ratings<sup>1)</sup> ( $T_A=25^{\circ}\text{C}$ , unless otherwise noted)

Parameter	Symbol	Ratings	Units
Input Voltage <sup>2)</sup>	$V_{IN}$	-0.3~9	V
Output Voltage <sup>2)</sup>	$V_{OUT}$	-0.3~ $V_{IN}+0.3$	V
Output Current	$I_{OUT}$	300	mA
Power Dissipation	SOT-23	0.4	W
	WFBFP-04C /DFN1X1-4L	0.4	W
	SOT-89	0.6	W
	TO-92	0.6	W
Operating Junction Temperature Range	$T_j$	-40~125	$^{\circ}\text{C}$
Storage Temperature	$T_{stg}$	-40~125	$^{\circ}\text{C}$
Lead Temperature(Soldering, 10 sec)	$T_{solder}$	260	$^{\circ}\text{C}$

- 1) Stresses beyond those listed under absolute maximum ratings may cause permanent damage to the device. These are stress ratings only, and functional operation of the device at these or any other conditions beyond those indicated under recommended operating conditions is not implied. Exposure to absolute-maximum-rated conditions for extended periods may affect device reliability.
- 2) All voltages are with respect to network ground terminal.

## Recommended Operating Conditions

Parameter	Min.	Nom.	Max.	Units
Supply voltage at $V_{IN}$	1.8		8	V
Operating junction temperature range, $T_j$	-40		125	$^{\circ}\text{C}$
Operating free air temperature range, $T_A$	-40		85	$^{\circ}\text{C}$

## Electrical Characteristics ( $V_{IN}=V_{OUT}+1V$ , $C_{IN}=C_{OUT}=1\mu F$ , $T_A=25^\circ C$ , unless otherwise specified)

Parameter	Symbol	Conditions	Min.	Typ. <sup>3)</sup>	Max.	Units	
Input Voltage	$V_{IN}$		1.8	—	8	V	
Output Voltage Range	$V_{OUT}$		1.2	—	5	V	
DC Output Accuracy		$I_{OUT}=1mA$	-2	—	2	%	
			-1	—	1	%	
Dropout Voltage	$V_{dif}^{4)}$	$I_{OUT}=100mA, V_{OUT}=3.3V$	—	110	—	mV	
Supply Current	$I_{SS}$	$I_{OUT}=0$	$1.2V \leq V_{OUT} \leq 3.3V$	—	0.8	1.3	$\mu A$
			$3.3V < V_{OUT} \leq 5.0V$	—	1.0	1.5	$\mu A$
Standby Current	$I_{STBY}$	$CE=V_{SS}$	—	—	0.1	$\mu A$	
Line Regulation	$\frac{\Delta V_{OUT}}{V_{OUT} \times \Delta V_{IN}}$	$I_{OUT}=10mA$ $V_{OUT}+1V \leq V_{IN} \leq 8V$	—	0.05	0.3	%/V	
Load Regulation	$\frac{\Delta V_{OUT}}{I_{OUT}}$	$V_{IN}=V_{OUT}+1V$ , $1mA \leq I_{OUT} \leq 100mA$	—	10	—	mV	
Temperature Coefficient	$\frac{\Delta V_{OUT}}{V_{OUT} \times \Delta T_A}$	$I_{OUT}=10mA$ , - $40^\circ C < T_A < 125^\circ C$	—	100	—	ppm	
Output Current Limit	$I_{LIM}$	$V_{OUT}=0.5 \times V_{OUT(Normal)}$ , $V_{IN}=5V$	550	700	850	mA	
Short Current	$I_{SHORT}$	$V_{OUT}=V_{SS}$	—	20	—	mA	
Power Supply Rejection Ratio	PSRR	$I_{OUT}=50mA$	100Hz	—	70	—	dB
			1kHz	—	50	—	
			10kHz	—	40	—	
			100kHz	—	35	—	
Output Noise Voltage	$V_{ON}$	BW=10Hz to 100kHz	—	$27 \times V_{OUT}$	—	$\mu V_{RMS}$	
CE "High" Voltage	$V_{CE"High"}$		1.5	—	$V_{IN}$	V	
CE "Low" Voltage	$V_{CE"Low"}$		—	—	0.3	V	
$C_{OUT}$ Auto-Discharge Resistance	$R_{DISCHRG}$	$V_{IN}=5V, V_{OUT}=3.0V$ , $V_{CE}=V_{SS}$	—	200	—	$\Omega$	

3) Typical numbers are at 25°C and represent the most likely norm.

4)  $V_{dif}$ : The Difference Of Output Voltage And Input Voltage When Input Voltage Is Decreased Gradually Till Output Voltage Equals To 98% Of  $V_{OUT}$  (E).

## Typical Application

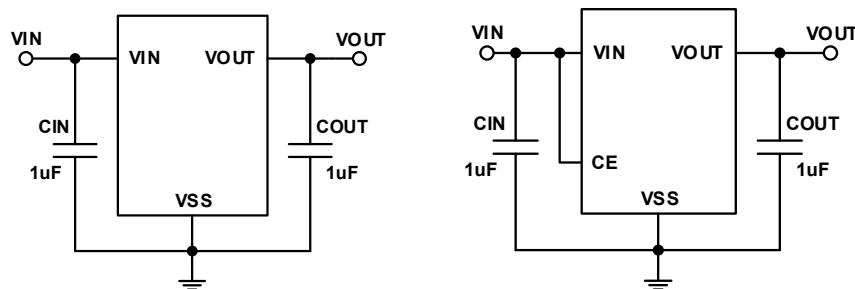

## Typical Performance Characteristics

### Output Characteristics

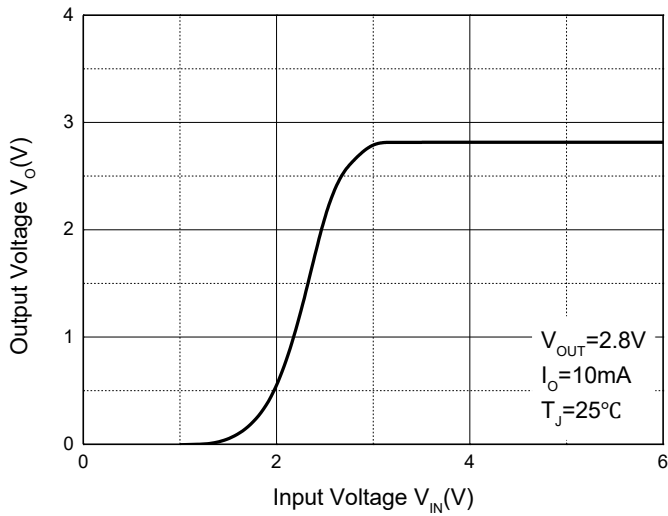

### Output Voltage vs. Temperature

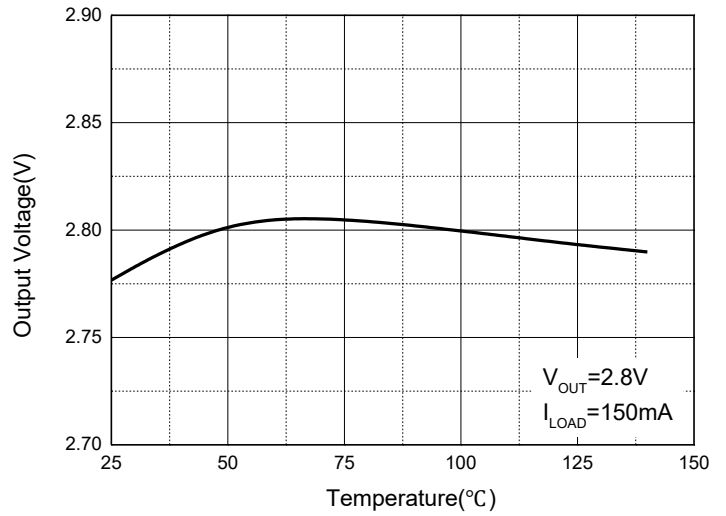

### Quiescent Current

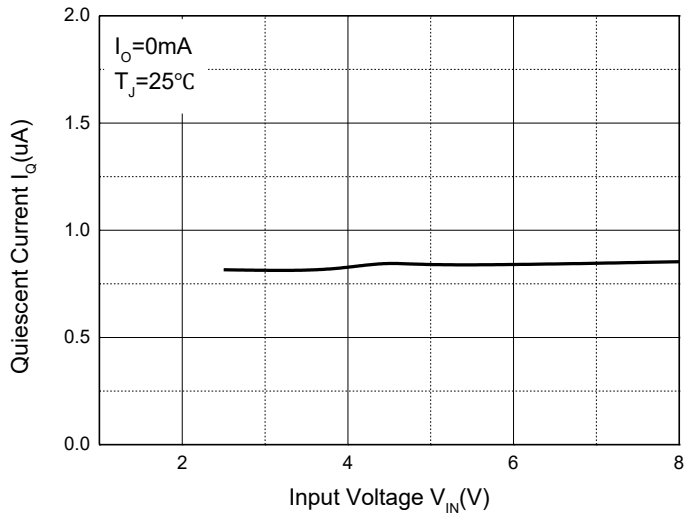

### Current Cut-off Grid Voltage

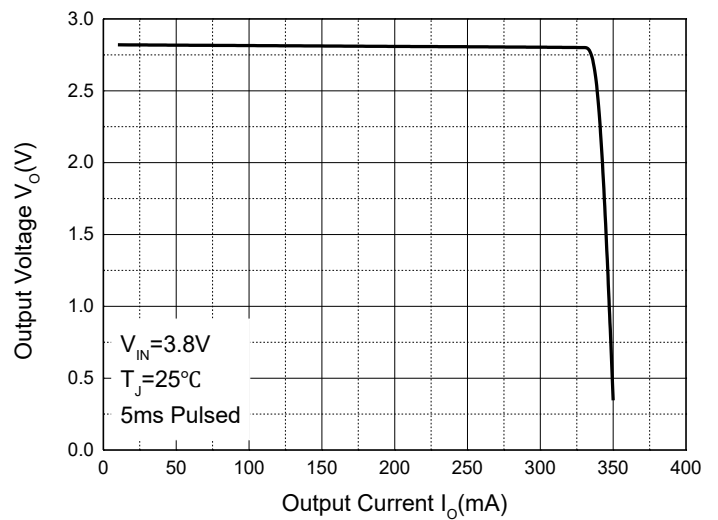

### Dropout Voltage vs. Load Current

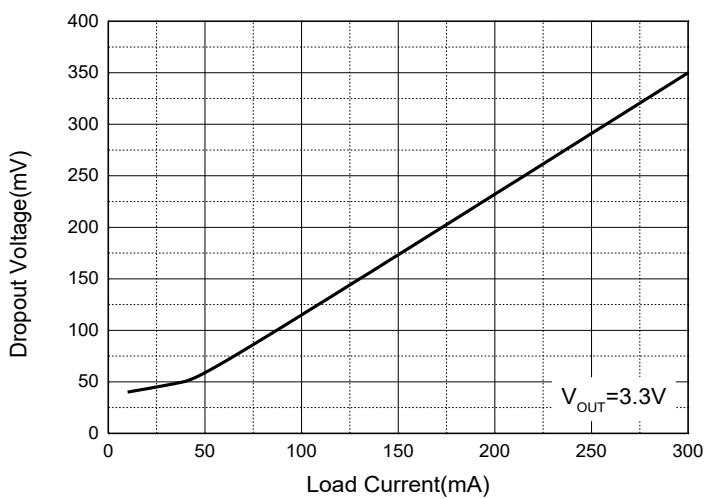

### PSRR vs. Frequency

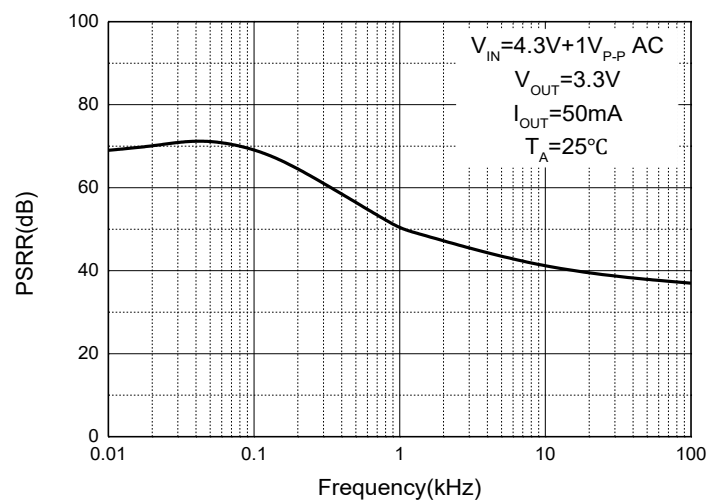

## SOT-23-3L Package Outline Dimensions

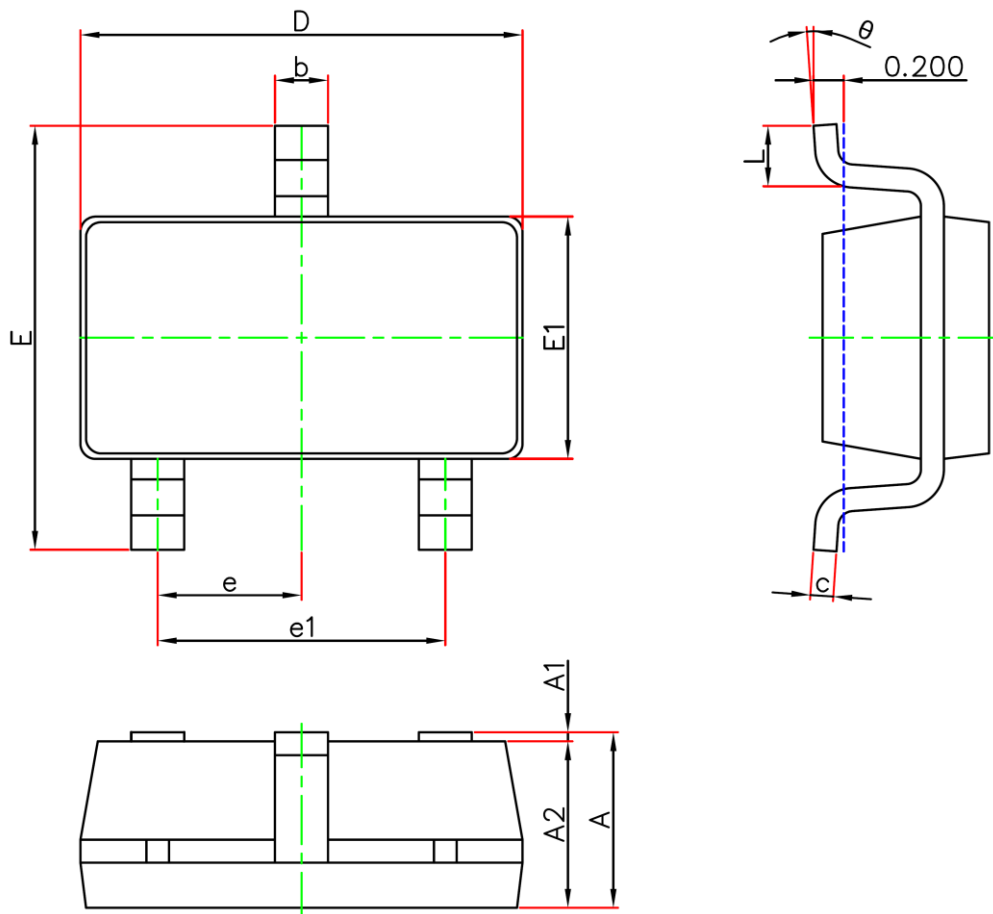

Symbol	Dimensions In Millimeters		Dimensions In Inches	
	Min.	Max.	Min.	Max.
A	1.050	1.250	0.041	0.049
A1	0	0.150	0.000	0.006
A2	1.050	1.250	0.041	0.049
b	0.300	0.500	0.012	0.020
c	0.100	0.200	0.004	0.008
D	2.820	3.020	0.111	0.119
E	2.650	2.950	0.104	0.116
E1	1.500	1.700	0.059	0.067
e	0.950TYP		0.037TYP	
e1	1.800	2.000	0.071	0.079
L	0.300	0.600	0.012	0.024
θ	0°	8°	0°	8°

## SOT-23-5L Package Outline Dimensions

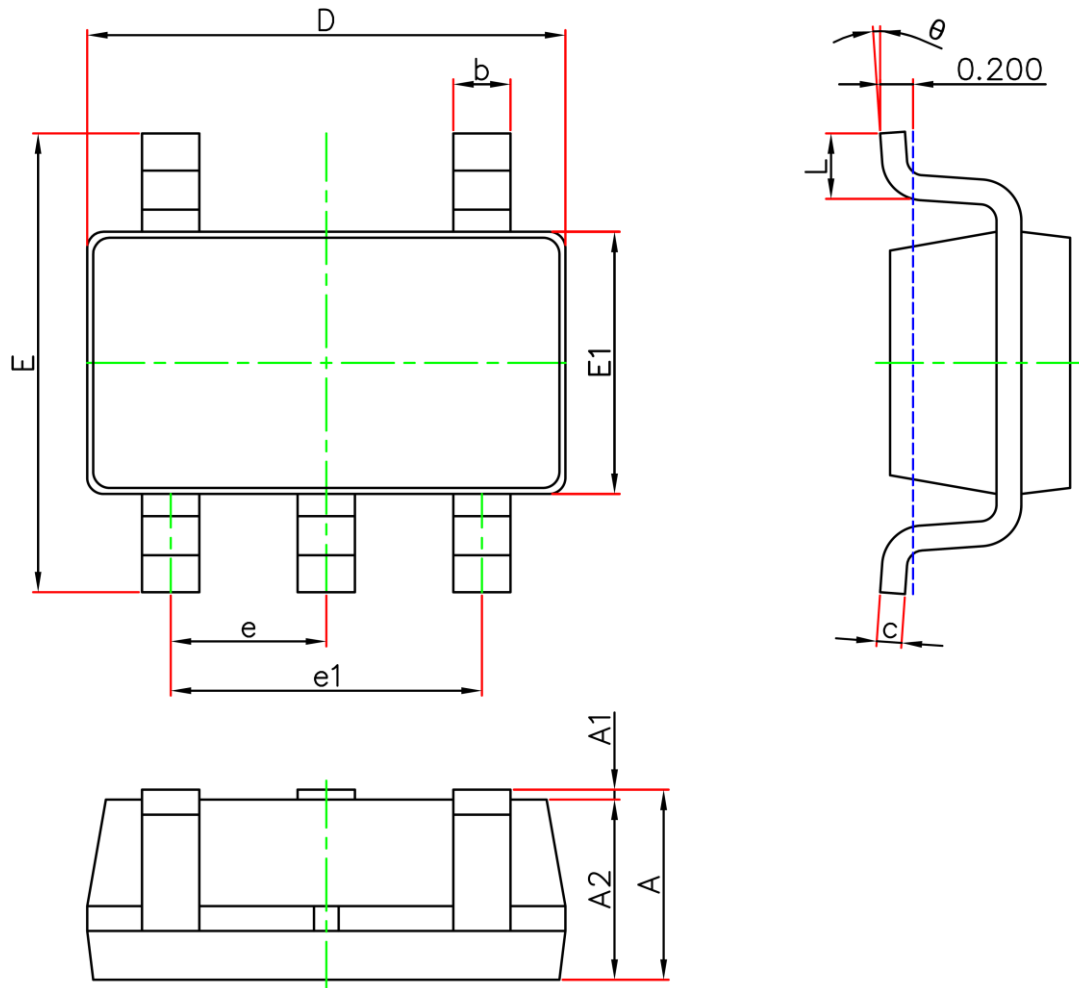

Symbol	Dimensions In Millimeters		Dimensions In Inches	
	Min.	Max.	Min.	Max.
A	1.050	1.250	0.041	0.049
A1	0	0.150	0.000	0.006
A2	1.050	1.250	0.041	0.049
b	0.300	0.500	0.012	0.020
c	0.100	0.200	0.004	0.008
D	2.820	3.020	0.111	0.119
E	2.650	2.950	0.104	0.116
E1	1.500	1.700	0.059	0.067
e	0.950TYP		0.037TYP	
e1	1.800	2.000	0.071	0.079
L	0.300	0.600	0.012	0.024
θ	0°	8°	0°	8°

## DFN1×1-4L Package Outline Dimensions

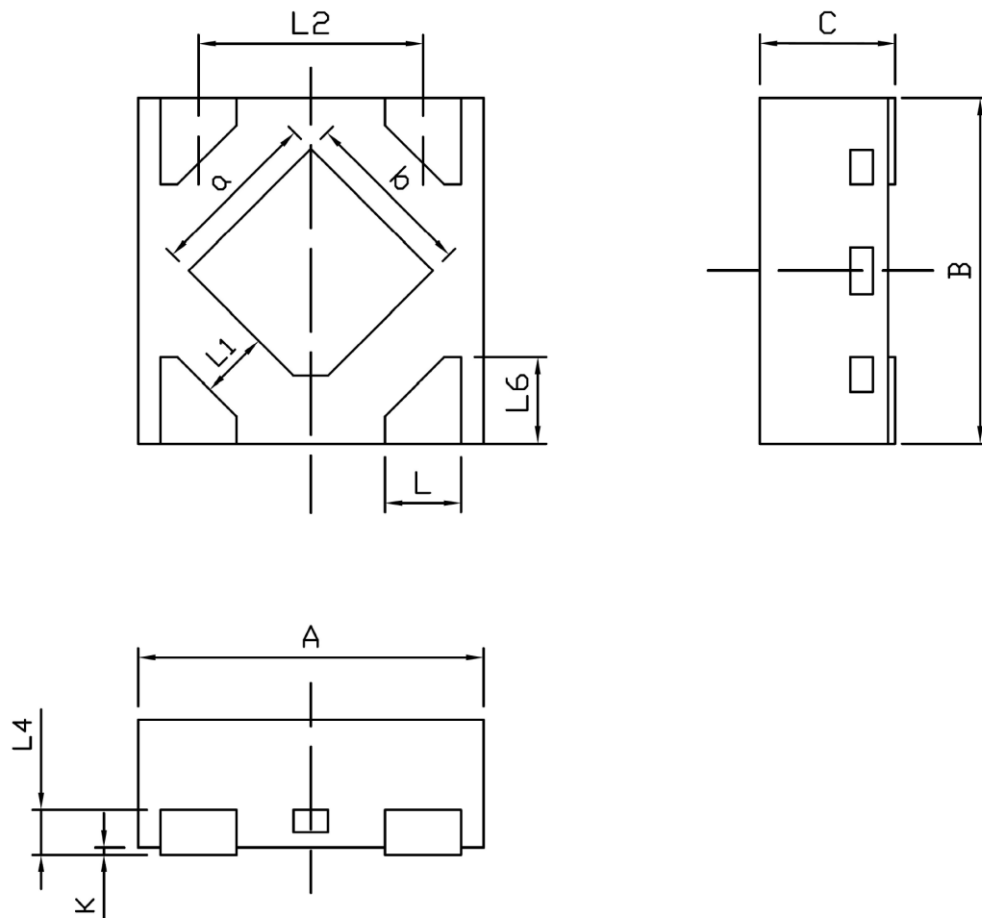

Symbol	Dimensions In Millimeters		Dimensions In Inches	
	Min.	Max.	Min.	Max.
A	0.950	1.050	0.037	0.041
B	0.950	1.050	0.037	0.041
C	0.340	0.400	0.013	0.016
L	0.150	0.250	0.006	0.010
L1	0.150MIN		0.006MIN	
L2	0.650BSC		0.026BSC	
L4	0.127REF		0.005REF	
L6	0.200	0.300	0.008	0.012
K	0.000	0.050	0.000	0.002
a	0.380	0.580	0.015	0.023
b	0.380	0.580	0.015	0.023



## SOT-89-3L Package Outline Dimensions

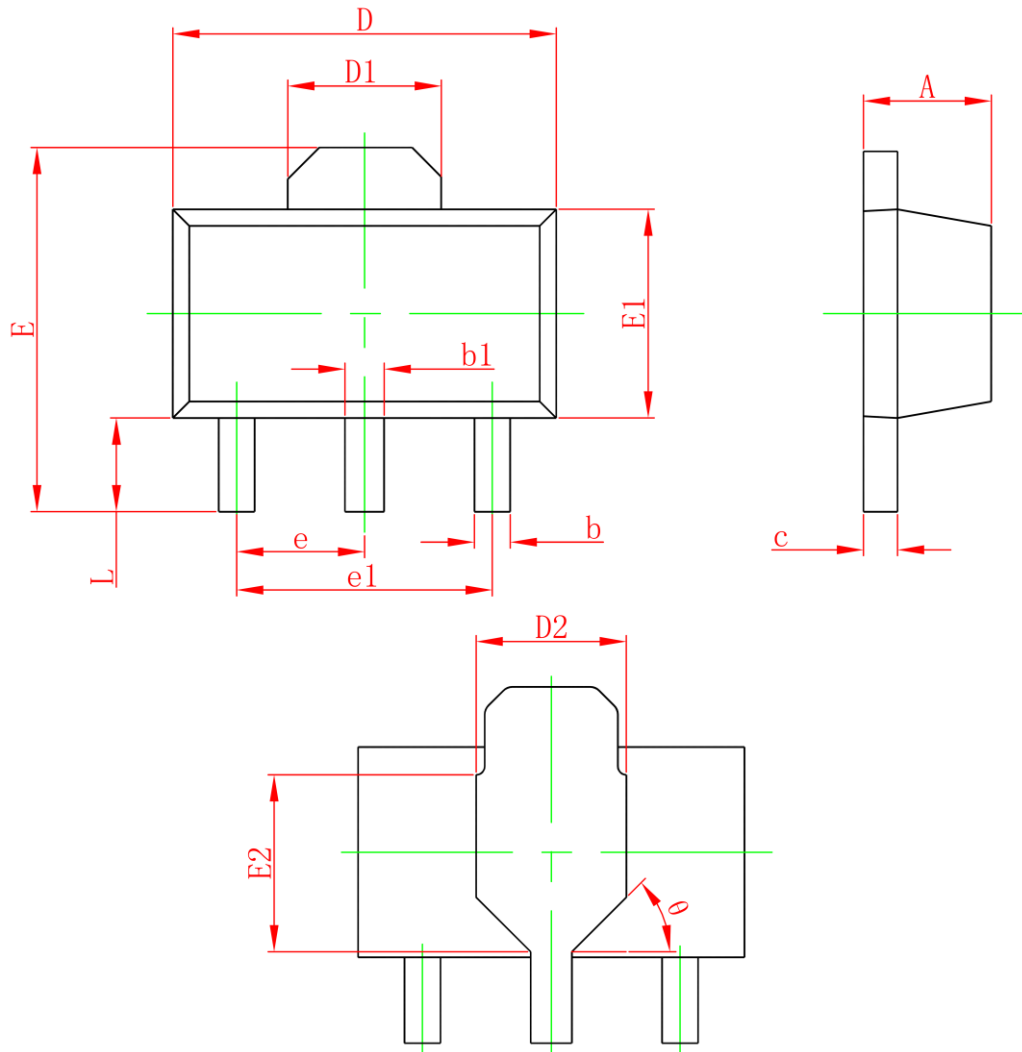

Symbol	Dimensions In Millimeters		Dimensions In Inches	
	Min.	Max.	Min.	Max.
A	1.400	1.600	0.055	0.063
b	0.320	0.520	0.013	0.020
b1	0.380	0.580	0.015	0.023
c	0.350	0.500	0.014	0.020
D	4.400	4.600	0.173	0.181
D1	1.650REF		0.065REF	
D2	1.650	1.850	0.065	0.073
E	3.900	4.400	0.154	0.173
E1	2.300	2.600	0.091	0.102
E2	1.900REF		0.075REF	
e	1.500TYP		0.059TYP	
e1	3.000TYP		0.118TYP	
L	0.900	1.200	0.035	0.047
θ	45°		45°	